

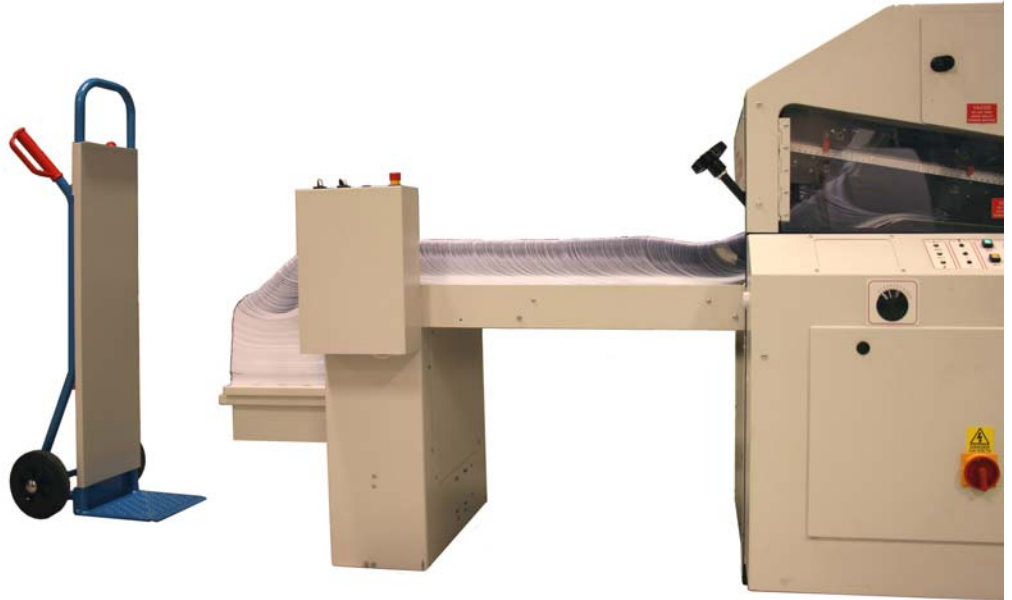

Data Sheet



ORION

Model

CF20/VST

Folder
Vertical
Stacking Table

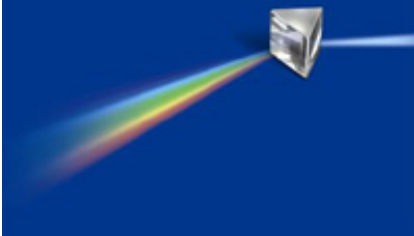

Matti Orion Ltd
Millstream Works, Station Road,
Wickwar, Gloucestershire, GL12 8NB
Telephone: +44 (0) 1454 294 526
www.mattiorion.com
info@mattiorion.com

The Matti **Orion** folding system provides a simple, proven method of generating continuous folded output from digital printers or any other continuous device.

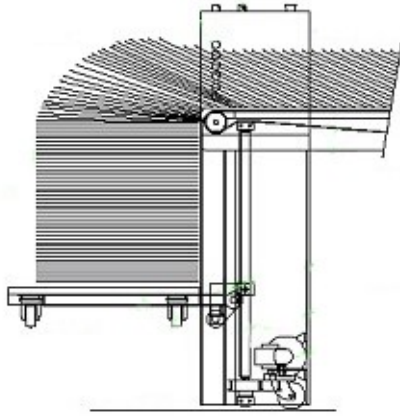

The Vertical Stacking Table allows the shingled delivery from the folder to be stacked in a vertical pack which facilitates a safe and easy transportation of the stack to its next operation.

As the pile height increases in the stacker the table automatically lowers. When the desired number of documents have been loaded, the dolly can be easily removed with a stack truck and pushed to its next process.

Main Features

- Allows a high volume of documents to be stacked.
- Increases folder and printer up-time.
- Automatic loading.
- Reduces operator stack manipulation
- Minimises potential repetitive strain injuries.

Model

CF20/VST

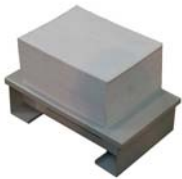

Dolly



Stack Truck

Benefits

- Reduces operator intervention.
- Minimises printer down time
- Increases stack capacity and improves handling
- Field up-gradable.
- Trouble free operation.

Optional Features

- 150 mtr Versions
- Pinless or Pinned processing
- Extension conveyor.
- Fast forward table.
- Mobile document transporter.
- Document pallets
- Dolly's
- Stack Trucks

Matti Orion
PRODUCT RANGE
Unwinders
Rewinders
Folders
Paper Processors
Dynamic Perforators
Die Cutters
Web Transport Systems

Orion Solutions

Millstream Works, Station Road, Wickwar,
Gloucestershire, GL12 8NB
Telephone: +44 (0) 1454 294 526, Facsimile: +44 (0) 1454 292 808
Internet Address: www.mattiorion.com
Email: info@mattiorion.com

Matti Technology AG

Industriestrasse 9, 8583 Sulaen, SWITZERLAND
Telephone: +41 71 424 09 60, Facsimile: +41 71 424 09 61
Internet Address: www.mattitech.ch
Email: info@mattitech.ch

Dealer: